

# EXPANDABLE OTN SWITCHING WITH APOLLO

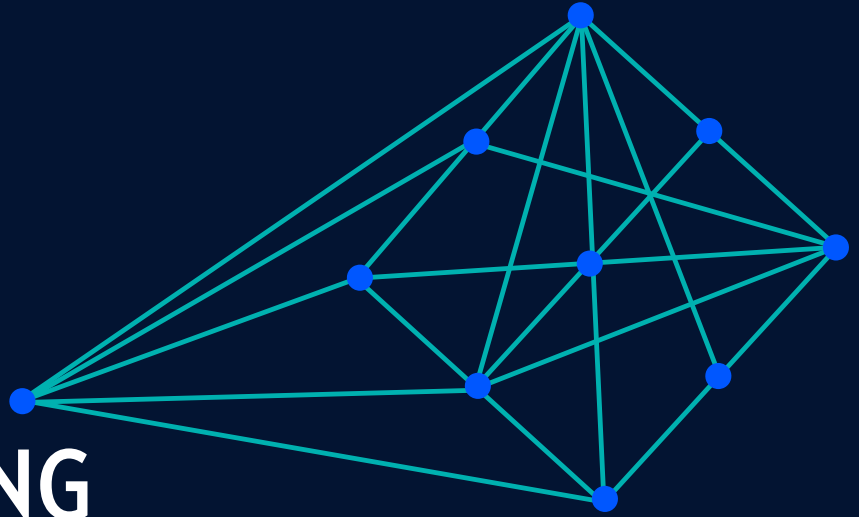

## IN-SERVICE NETWORK EFFICIENCY IMPROVEMENT

OTN subrate switching can improve the overall efficiency of optical networks significantly. However, in smaller or metro networks with constant fluctuations in demand, the planning of the location and size of OTN networking equipment can be a challenge.

Apollo's expandable OTN switching allows OTN switching capacity to be deployed where and when it is needed in your network, providing in-service network efficiency that handles fluctuating demand smoothly.

### Scalable

switching capacity  
where you need it

### Flexible

unrestricted service  
moves

### Efficient

maximum fill of  
100G wavelengths

### Cost Effective

pay-as-you-grow  
capability

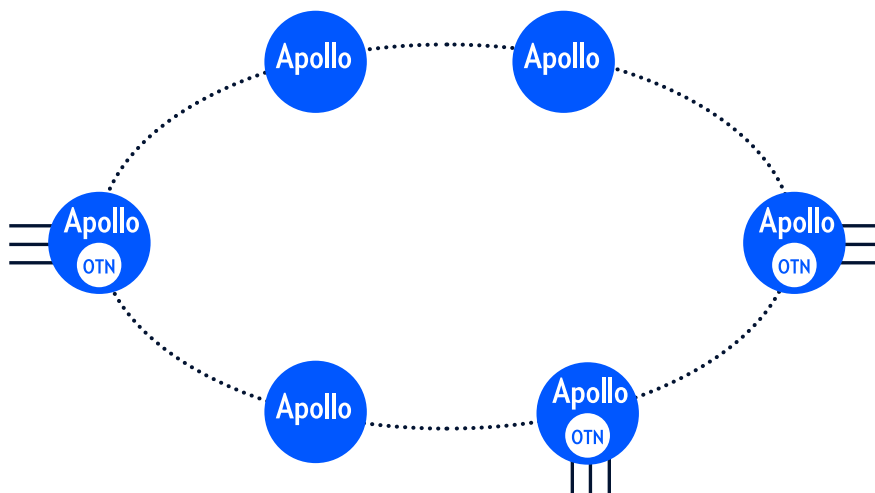

# OTN SWITCHING

OTN technology is designed to allow encapsulation and routing of lower-speed signals onto a common, high-speed optical network. Services from Ethernet to Fibre Channel to SONET/SDH and more, can be combined efficiently and easily on a common DWDM network, using OTN technology. OTN is especially well-designed for efficiently packing high-speed optical lines, such as 100Gbps wavelengths, in networks with many smaller service demands. This is because the smaller signals can be encapsulated into standard payloads that stack well into larger ones.

Adding OTN to a WDM network not only improves overall efficiency, but provides a way to segment networks into self-contained slices, dedicated to specific service types, customers, or areas of interest. Contrasted with packet technologies, each OTN container is an end-to-end connection-oriented pathway that can be defined, protected, and managed uniquely.

OTN switching enhances OTN networks by allowing the sub rate signals within a larger OTN bundle to be moved around flexibly between client locations and high-speed bandwidth lines. This capability is especially useful in networks with abundant lower-speed signals and churn (new services added, changing service locations), because it leverages the common network resources as efficiently as possible. Rather than requiring all encapsulated services to be terminated at the same point, OTN switching allows individual services to be extracted from the larger container and added/dropped flexibly at intermediate sites. This capability ensures that the network wavelengths remain as fully utilized as possible, even on a network with a variety of demands at multiple sites.

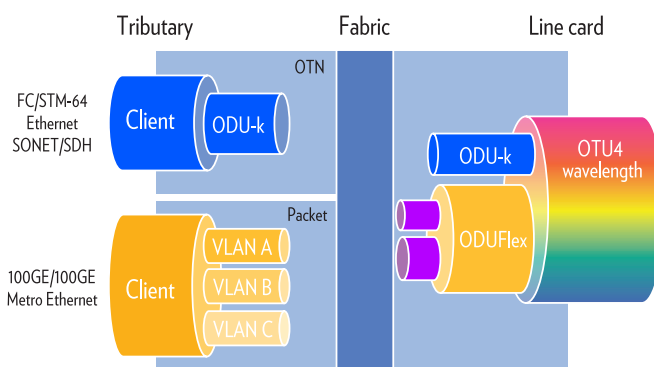

## APOLLO OTN SWITCHING OPTIONS

ECI's Apollo product line offers a full set of OTN switching solutions from the access to the core. Solutions include:

- **10G ADM on a card:** A complete, dual-line 10G ADM with 16 multi-rate clients and full OTN switching, perfect for aggregation and add/drop applications in the optical access.
- **Core OTN switching platforms:** Available as a 5.6Tbps rack or a full 16Tbps bay, the Apollo core OTN switching platforms form the basis for a fully-flexible, switched OTN core.
- **Expandable metro OTN switching:** The expandable switching capability allows OTN switching to be added economically in 200Gbps increments, up to 800Gbps per shelf, for a pay-as-you-grow option in parts of the network that can use OTN switching for enhanced efficiency.

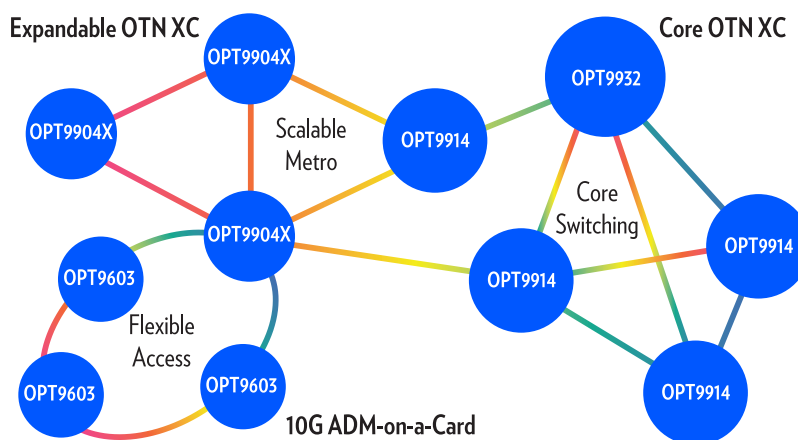

# EXPANDABLE OTN SWITCHING

The Apollo 9904X platform offers a unique expandable OTN interface and switching block, from 200Gbps to 800Gbps, which can be deployed on an as-needed basis in metro networks. Each block supports up to 200Gbps of switching with one 100Gbps line interface and twelve multi-service client interfaces. The client interfaces support a wide range of signal types including SAN, Ethernet, SONET/SDH, and OTN - up to 10Gbps per client.

Deploying a single OTN block activates the first fully-flexible, non-blocking 200Gbps of OTN switching capacity. Adding a second block makes the entire shelf into a non-blocking 400Gbps OTN switch, with full switching flexibility between ports. The third and fourth blocks expand the capacity to 600Gbps and 800Gbps, respectively, with a fully-meshed backplane ensuring non-blocking operation. The Apollo 9904X backplane is scaled to support up to 400Gbps per

slot in the future, which will enable expandable OTN switching that scales to 1.6Tbps per shelf.

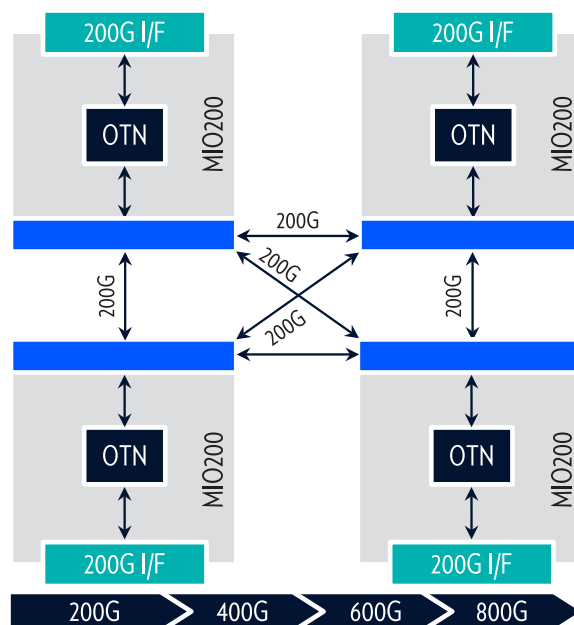

## NETWORK EXAMPLE

In the metro example shown, the core network is a 100Gbps DWDM ring consisting of six nodes. In this network, there are four customers located around the ring with demands ranging from two 10GbE services to five 10GbE services per customer. The demands are distributed around the ring and, therefore, cannot be carried end-to-end via traditional muxponders. By deploying OTN switching in just two locations (B and C), all the traffic from these four customers can be carried on a single 100G wavelength. Traffic enters the ring at sites A and E via traditional OTN-based muxponders. At sites D and F, where no traffic is added or dropped, no OTN switch fabric is required and traffic can pass through at the wavelength layer. At sites B and C, an expandable OTN switch is used to add/drop the necessary traffic in/out of the 100G wavelength – two 10G services added at site B, five 10G services dropped, and five added at site C.

Without OTN switching, the traffic from these four customers would require four wavelengths. With OTN switching, only one is required. Thus, OTN switching improves the efficiency for the demands listed in this simple network example by a factor of four.

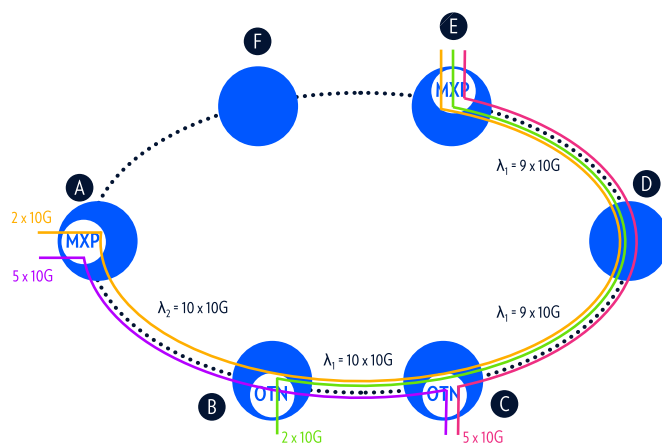

With expandable OTN, the two sites with OTN switches can be built using just enough switching capacity to support the traffic requirements. If more demand is added to the network – either a new customer or an expansion of demand from an existing customer – additional OTN switching can be added as needed, easily and economically.

For example, if a new wavelength is added at Site A that contains nine 10G connections to Site B and one to Site C (as shown in the diagram), additional OTN switching capacity can be added only at Site B and no other network modifications are needed. No additional

wavelengths are needed between Sites B and C, as the spare capacity that already exists can be used efficiently.

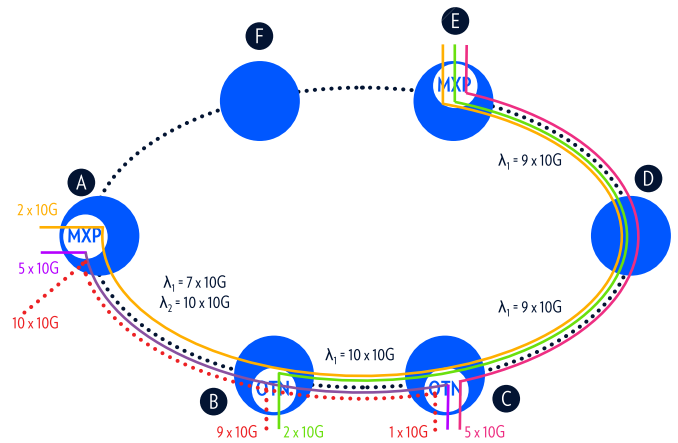

## A BIGGER BANG FOR YOUR BUCK

OTN switching technology has the ability to greatly improve the efficiency of WDM-based networks by enhanced wavelength utilization. Expandable OTN switching brings these efficiencies to metro and campus networks with their varied demands, and which may not require a full OTN switch at every location. By economically adding only the switching capacity that is needed, and only in the locations where it is needed, the Apollo 9904X expandable switching platform is the ideal way to improve efficiency and reduce costs in these networks.

Contact us to find out how our ELASTIC networks can help you grow



### ABOUT ECI

ECI is a global provider of ELASTIC network solutions to CSPs, utilities as well as data center operators. Along with its long-standing, industry-proven packet-optical transport, ECI offers a variety of SDN/NFV applications, end-to-end network management, a comprehensive cyber security solution, and a range of professional services. ECI's ELASTIC solutions ensure open, future-proof, and secure communications. With ECI, customers have the luxury of choosing a network that can be tailor-made to their needs today – while being flexible enough to evolve with the changing needs of tomorrow. For more information, visit us at [www.ecitele.com](http://www.ecitele.com)